



INSTALLATION INSTRUCTIONS

Accessory	Application	Publications No.
SECURITY SYSTEM	2014 RIDGELINE	All 50356
		Issue Date AUG 2013

PARTS LIST

Security System Attachment Kit: P/N 08E55-SJC-101

Unit bracket

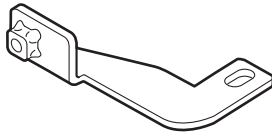

Security harness

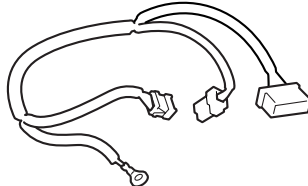

10 Wire ties

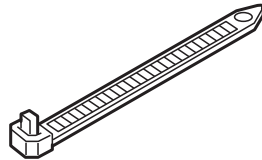

Fuse (2A)

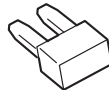

LED



2-pin Connector

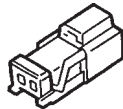

2 Cushion tapes

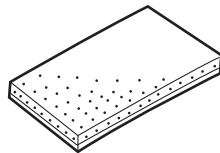

Fuse label

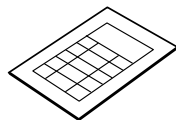

Flange bolt

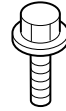

Information manual



Security System Kit (sold separately) P/N 08E51-SHJ-101

Security unit

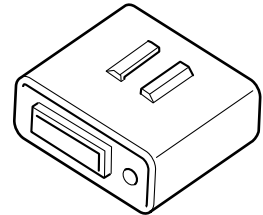

Security label

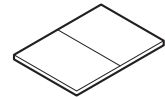

Microphone

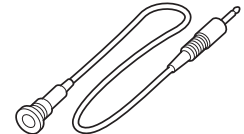

TOOL AND SUPPLIES REQUIRED

#2 Phillips screwdriver

Felt-tip pen

8 mm and 10 mm Socket

Ratchet

3 mm, 6 mm, and 8 mm Drill bits

Eye protection (face shield, safety goggles, etc.)

File

Diagonal cutters

Tape measure

Drill

Isopropyl alcohol

Shop towel

Scissors

Illustration of the Security System in the Vehicle



INSTALLATION

Customer Information: The information in this installation instruction is intended for use only by skilled technicians who have the proper tools, equipment, and training to correctly and safely add equipment to your vehicle. These procedures should not be attempted by “do-it-yourselfers.”

1. Make sure you have the anti-theft code for the radio, then write down the radio station presets.
2. Disconnect the negative cable from the battery.

3. Remove the dashboard left side cover (seven clips).

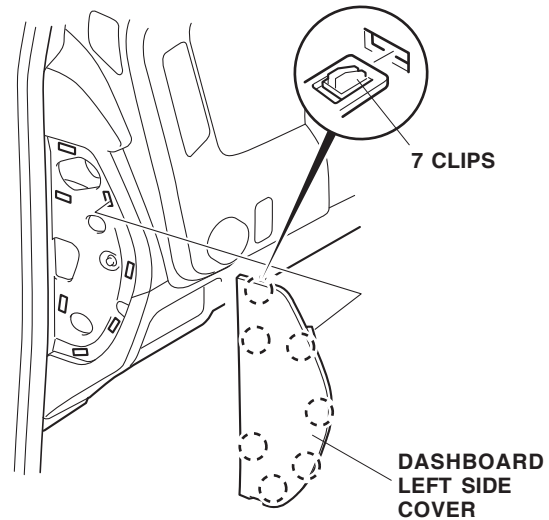

4. Remove the driver's dashboard lower cover:
 - Remove the one self-tapping screw.
 - Release the nine clips, and pull out the driver's dashboard lower cover.
 - Unplug the vehicle connectors, and remove the lower cover.

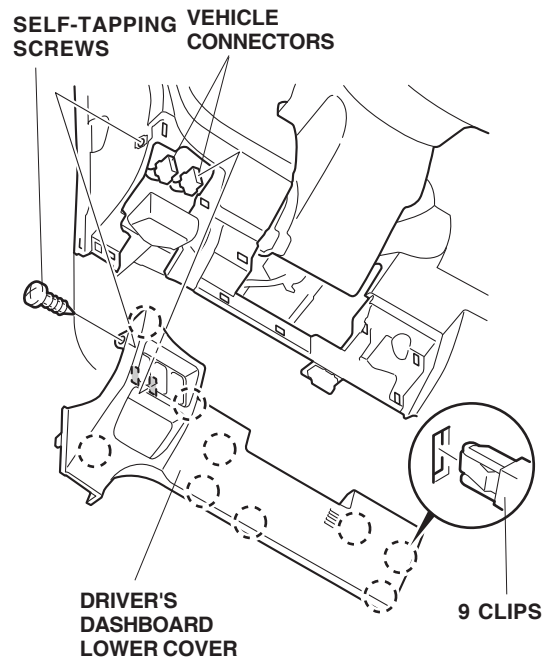

5. Using a tape measure and felt-tip pen, measure and mark the driver's dashboard lower cover.

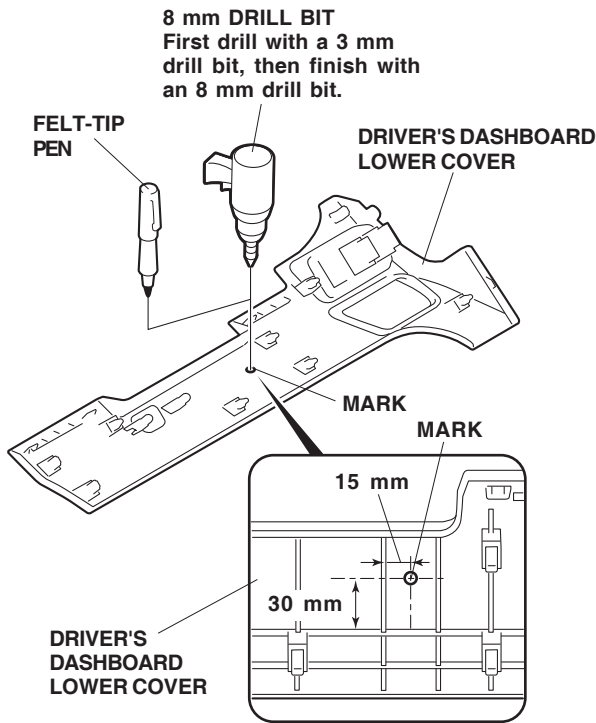

6. While wearing eye protection, drill an 8 mm hole through the mark. First drill with a 3 mm drill bit, then finish with an 8 mm drill bit. Remove all burrs.
7. Route the microphone jack through the hole you just drilled, and secure the microphone in the cover.

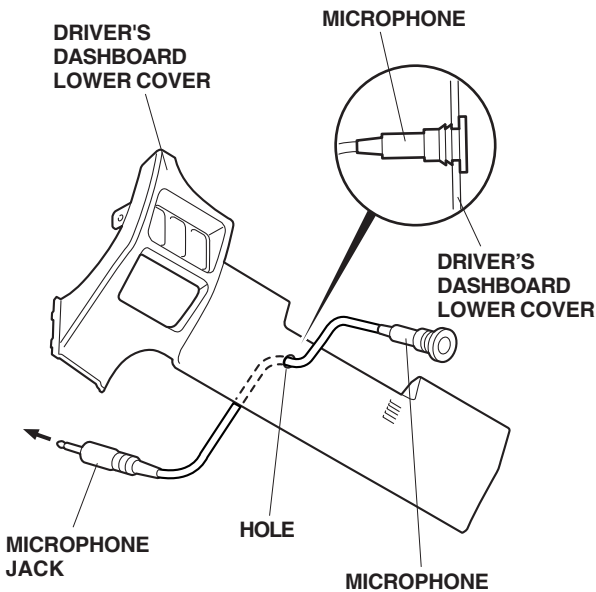

9. Remove the upper and lower steering column covers:

- Carefully pry up on the six retaining tabs to loosen the upper steering column cover.
- Remove the shift lock release cover (four retaining tabs). Insert the ignition key into the shift lock release, and move the shift lever to the "N" position while pressing down on the key.
- Remove the key, and lift up on the upper steering column cover. Pull the cover toward you, and remove it by lowering the shift lever to the "1" position.
- Remove the two self-tapping screws and one screw, and remove the lower steering column cover.

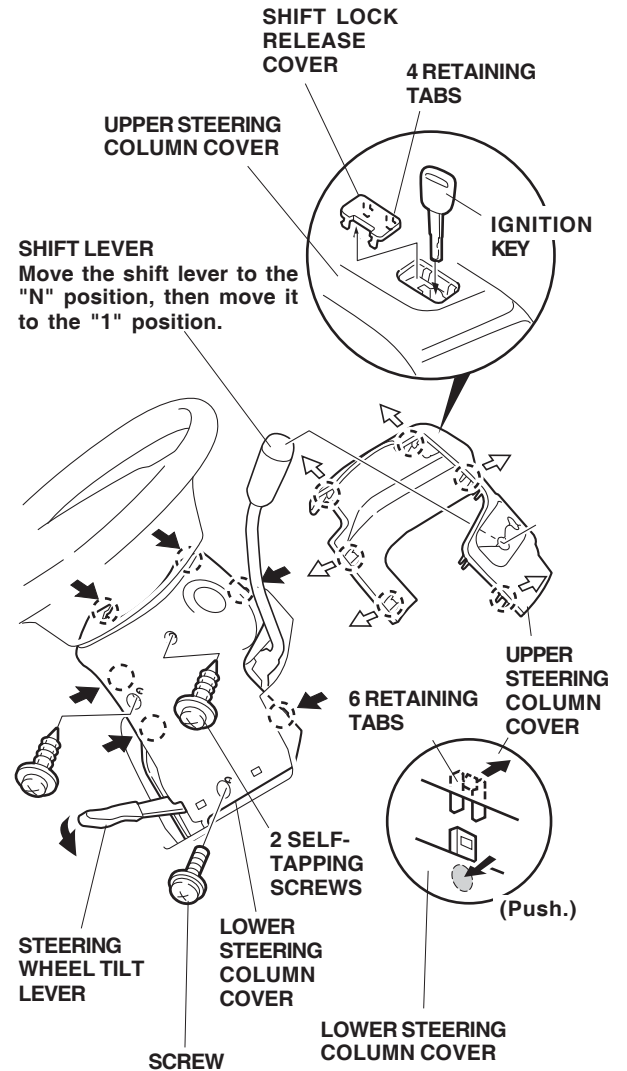

10. Using a tape measure and felt-tip pen, measure and mark the steering column upper cover.

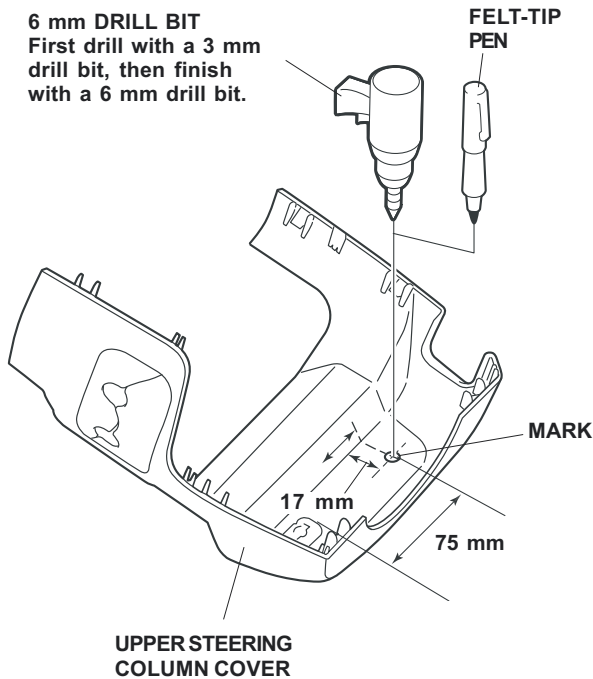

11. While wearing eye protection, drill a 6 mm hole through the mark. First drill with a 3 mm drill bit, then finish with a 6 mm drill bit. Remove all burrs.
12. Route the terminal ends of the LED through the hole you just drilled in the cover, and secure the LED in the cover.

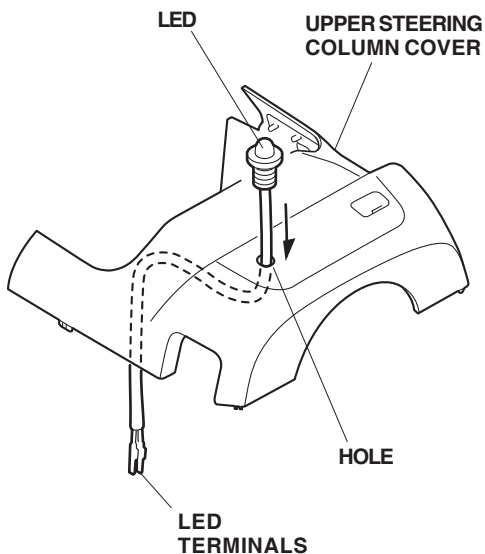

13. Get the 2-pin connector from the kit. Firmly push the LED terminals into the 2-pin connector until they click into position, then lower the lock.

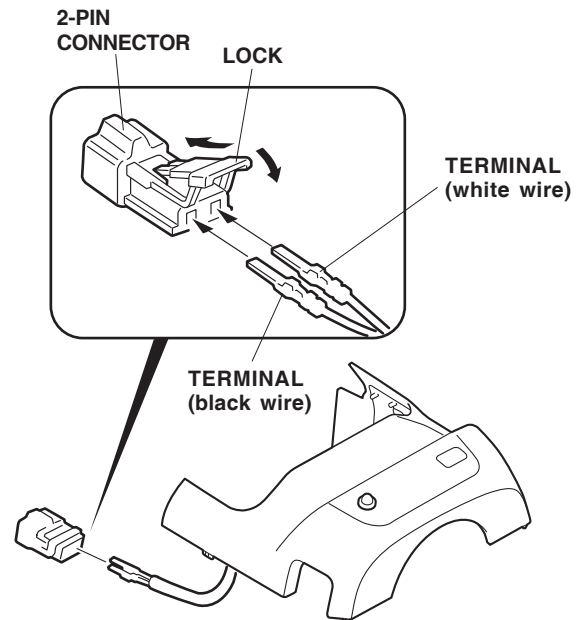

14. Plug the security harness 6-pin connector to the fuse box 6-pin connector.

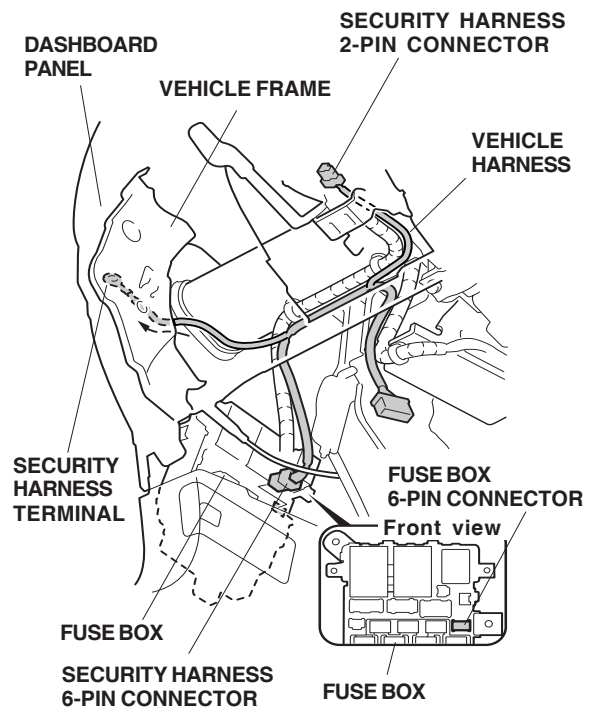

15. Route the security harness 2-pin connector along the vehicle harness. Route the security harness terminal between the vehicle frame and dashboard panel.

18. Remove the vehicle ground bolt, and attach the security harness ground terminal using this bolt.

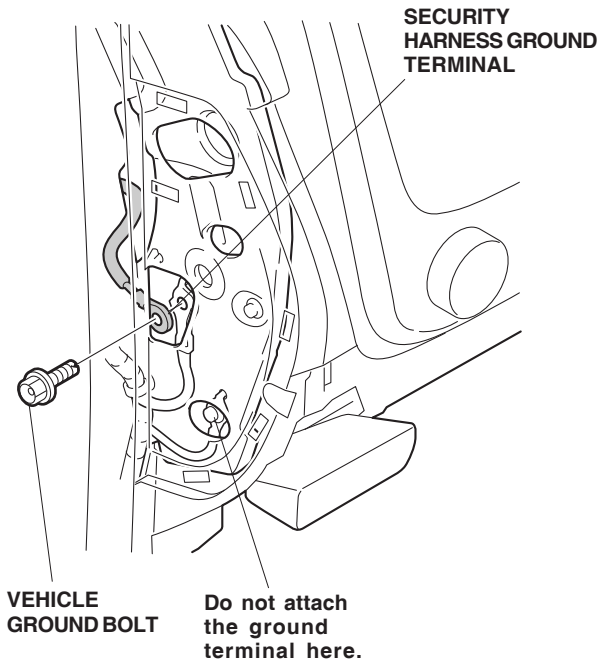

19. Secure the security harness to the gauge harness with four wire ties in the area shown.

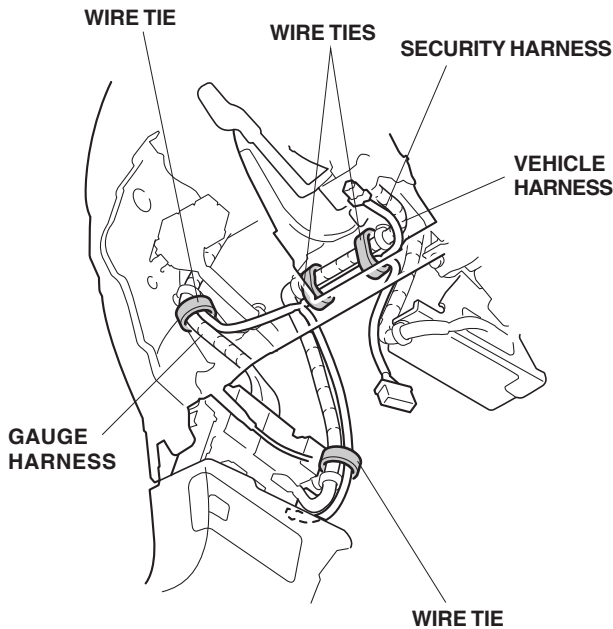

20. Position the upper steering column cover above the steering column, and plug the security harness 2-pin connector into the LED 2-pin connector.

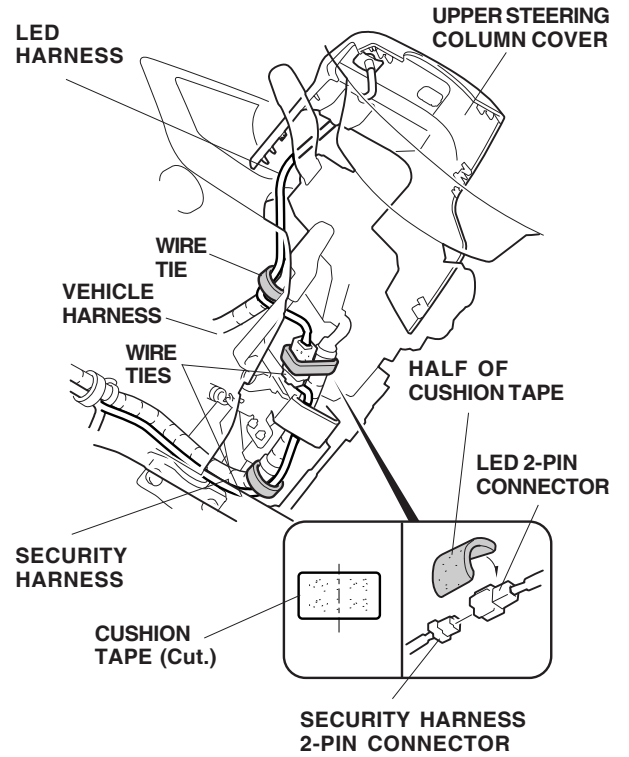

21. Using scissors, cut one cushion tape in half. Wrap the cut cushion tape around the connector. Secure the LED connector and the harness to the vehicle harness with three wire ties.
22. Reinstall the steering column covers.
23. Using scissors, cut a 15 x 50 mm piece of cushion tape. Attach the cut piece of cushion tape to the security unit at the location shown.

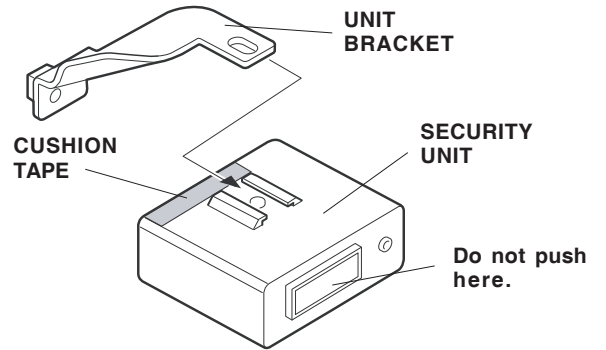

24. Insert the unit bracket into the security unit. Do not push at the connector area.

25. Using isopropyl alcohol on a shop towel, clean the area where the cushion tape will attach. Using scissors, cut a slit in the remaining half of cushion tape, and attach it to the security unit as shown.

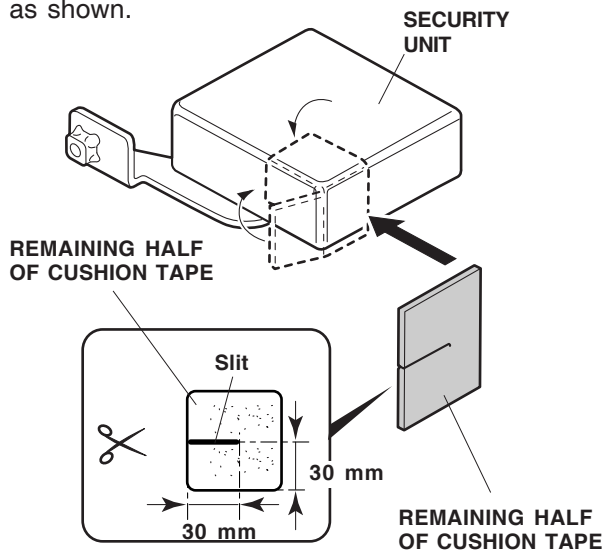

26. Under the dash, install the security bracket to the vehicle frame with the flange bolt provided.

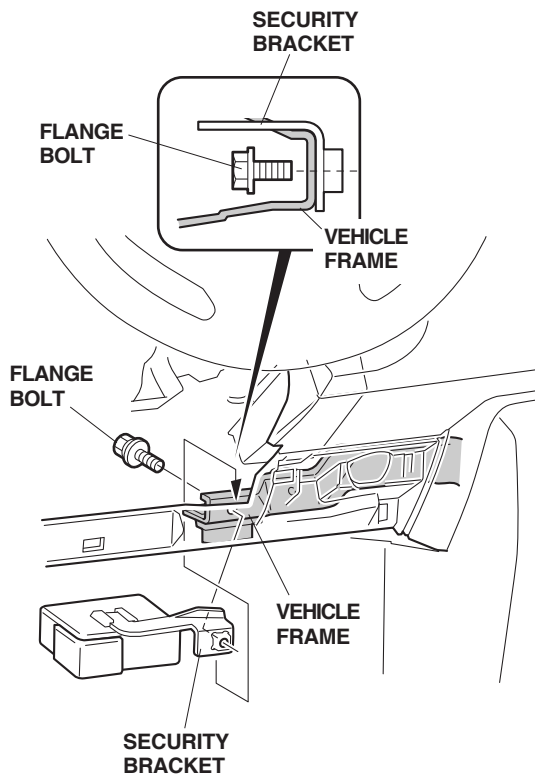

- If the vehicle is equipped with backup sensors;* remove the wire tie that fastens the backup sensor harness. Wrap one cushion tape around the backup sensor harness, and secure the backup sensor harness to the unit bracket with the wire tie you removed.

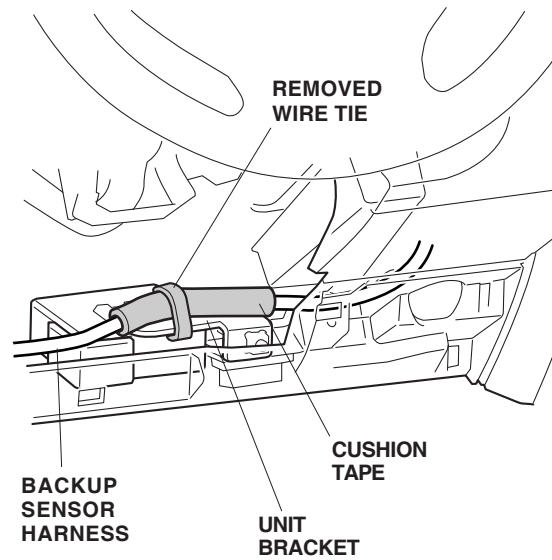

27. Reinstall the dashboard lower cover. Plug the security harness 18-pin connector and the microphone jack into the security unit.

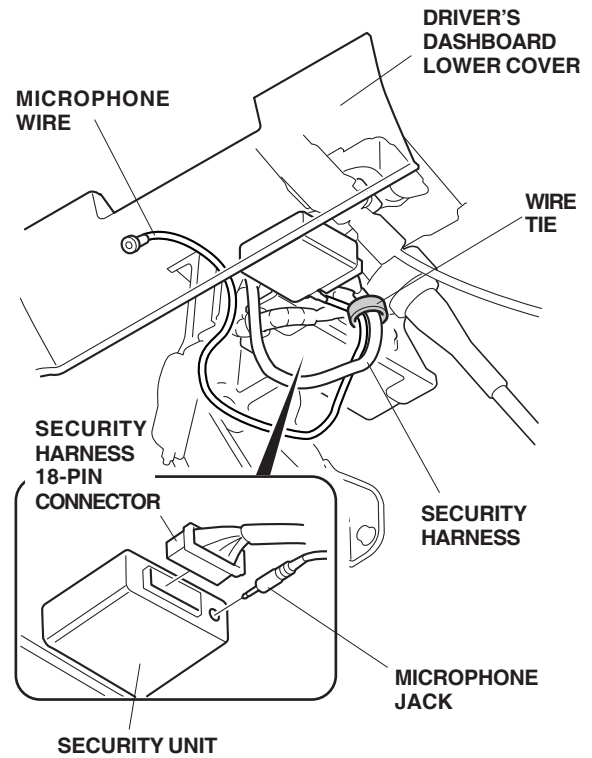

28. Fold the security harness and microphone wire, and secure them with one wire tie with no tension on the microphone jack.

29. Fold the excess length of the microphone wire, and secure it to the vehicle harness with two wire ties.

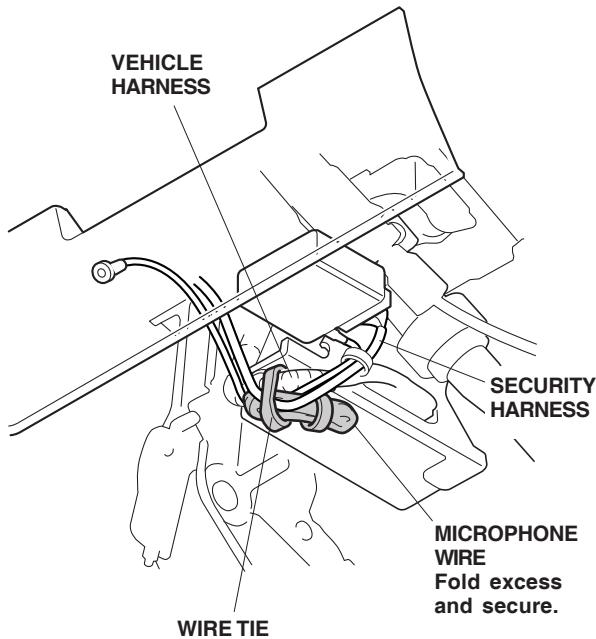

30. Slide the fuse box cover forward, and remove it. Install the 2A fuse into the No.33 slot in the fuse box.

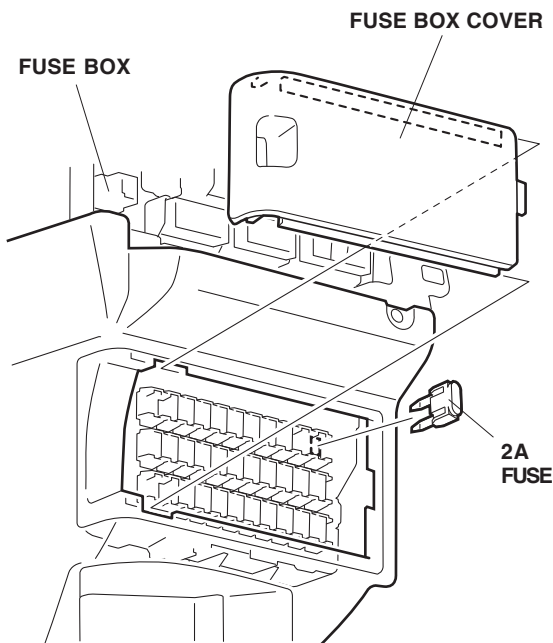

31. Attach the fuse label (OPTION FUSE 2A) over the No.33 slot on the inside of the fuse box cover.

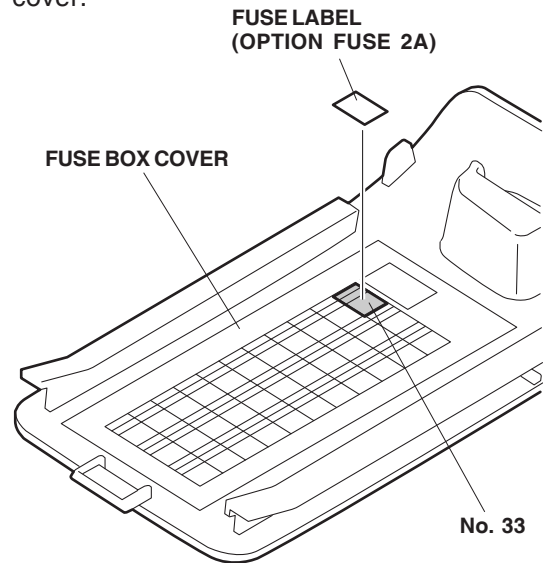

32. Check that all wire harnesses are routed properly and all connectors are plugged in.
32. Reinstall all removed parts.
34. Reconnect the negative cable to the battery.
35. Enter the customer's radio anti-theft code, and reset the radio station presets.
36. Reset the clock.
37. Check the operation of the security system according to the Security System Information manual.

NOTE: Whenever the battery is disconnected, the driver's window AUTO function is disabled.

38. Start the engine. Push down on the driver's window switch until the window is fully open.
39. Pull up on the driver's window switch fully to close the window completely, then hold the switch for 2 seconds or more.
40. Test the window AUTO function.
41. Install one security system window sticker to the lower right corner of the driver's window and one sticker to the lower left corner of the passenger's window.